INSTALLATION & OPERATION

PCR-1830 MOTOR LOAD CONTROL

- Senses power going to a motor, machine or process
- Activates an output or "trips" when the selected power levels are reached

FEATURES

3 ADJUSTABLE SET POINTS

When power reaches your selected SET POINT a built-in Relay Output is activated (tripped). Relay stays tripped (latched). You choose when to reset. The characteristics of these Set Points can be changed.

ANALOG OUTPUT

Hook to the Load Meter for monitoring load, easy setup and adjustment.

EASY SETUP WITH SET READ SWITCHES

Press the SET READ Switch and the SET POINT for that Channel is displayed on the LOAD METER.

- You **know** where the SET POINT is
- Easily verify proper operation

BUILT-IN START-UP TIMER

Adjustable Timer eliminates false trips while the Motor is starting.

FILTER OUT NUISANCE TRIPS

Adjustable On-Delay Timer. Trip won't activate until the selected delay time is exceeded. The On Delay for Set 1 can be defeated.

RESET

The Control can be Reset

- Automatically — when the overload is gone.
- Remotely — with switch, relay or programmable controller
- Manually

TRIP INHIBIT

The Control can be remotely bypassed during any part of the cycle when not required.

Also Available

Remote Set Point Adjustment

POWER

These Controls have a built-in fast response Power Sensor

- Voltage is taken from two of the phases
- Current (amperage) is taken from the remaining phase
- Power Factor is calculated from the lag of the current behind the voltage

THREE PHASE POWER = VOLTS X AMPS X POWER FACTOR X 1.73

SET POINT CHARACTERISTICS

REGULAR SET POINTS

The relays trip when a Set Point is reached. Set Points can be:
High Trip — Trips when the power goes above the Set Point
Low Trip — Trips when the power goes below the Set Point
All 3 Set Points can be Regular. Set 1 can be high or low.

COMPENSATOR™ SET POINTS

For machine tool applications such as grinder gap elimination or dull tool detection the drifts in idle or "BASELINE" power should be zeroed out.

- A limit switch or programmable controller signal tells the COMPENSATOR™ each time the machine is in the idle or "BASELINE" position.
- The COMPENSATOR™ samples this power level and retains it as a reference.
- The SET POINTS are related to this BASELINE.

In other words, the COMPENSATOR™ zeroes out the BASELINE power for each cycle. The absolute trip point changes as conditions change but always remains a fixed amount away from the BASELINE. This means no constant fine tuning. It adjusts itself. Set 1 and Set 2 can be compensated.

Adjustment Ranges for Set Points

3%-50% — Expands the adjustment range to provide more sensitivity and precision at low loads (especially for COMPENSATED Set Points)

6%-100% — For General Use

On Delay — For Set 1, the Trip Delay can be removed from the circuit for maximum response speed - useful for grinder gap elimination.

CHANGING CHARACTERISTICS

The factory settings for the characteristics are marked on the Control adjacent to the Serial Number on the side. To change them, remove the cover (4 Phillips screws) and find the 6 Position DIP SWITCH.

SWITCH POSITIONS

Set 1		Set 2	
COMPENSATED	Switch 2 OFF	COMPENSATED	Switch 6 OFF
Regular	2 ON	Regular	6 ON
High Trip	3 OFF	3%-50% Range	5 ON
Low Trip	3 ON	6%-100% Range	5 OFF
3%-50% Range	1 ON		
6%-100% Range	1 OFF		
Defeat On Delay	4 OFF		

Set 3 is always Regular with 6%-100% Range.

INSTALLATION

MOUNTING

The Load Control should be mounted in a control cabinet or in a protected area. The four Phillips head screws on the Control should be removed and used for attaching the mounting brackets to the Control. High voltage is present on the upper terminal strips. If regular access to the Control is needed in this case, these terminals should be covered.

ELECTRICAL CONNECTIONS

VOLTAGE

120 Volts AC - 35VA minimum is taken from two of the phases. If the machine already has a 120 Volt control transformer with 35 VA of free capacity, this can be used. Otherwise, install a separate transformer. Be sure to note which two phases supply the transformer.

CURRENT

The current signal is taken from the **REMAINING** phase. There is a current sensing toroid inside the control and up to 15Amps can be passed directly through the control. The normal control has full scale capacities of 3.75, 5 and 15 Amps built-in. Above 15 Amps, an external current transformer reduces the signal to 5 Amps which is then passed through the control. For small motors, the control can easily be factory modified. A standard modification is .75, 1.0, 3.0 Amps full scale.

It is **VERY IMPORTANT** that the current signal comes from the phase that IS NOT supplying the 120V control transformer. Be extra careful when the machine has reversing starters or multi-speed windings. If a wrong phase is used the control will either:

- Work backwards
- Have reduced sensitivity.

CAPACITY

Below 2 Amps
3.75 Amps
5 Amps
15 Amps
Above 15 Amps Use
xxx: 5 Current Transformer

CONNECT CURRENT TO TERMINALS

*MODEL "1.0" Factory Modification
5A and 15A
COM and 5A
COM and 15A
COM and 5A

*For Small Motors
Specify Suffix "1.0"
Full Scale 1.5 Amp, 2.5 Amp, 3.75 Amp

ELECTRICAL CONNECTIONS (Continued)

Up to 15 Amps Directly
Through Control

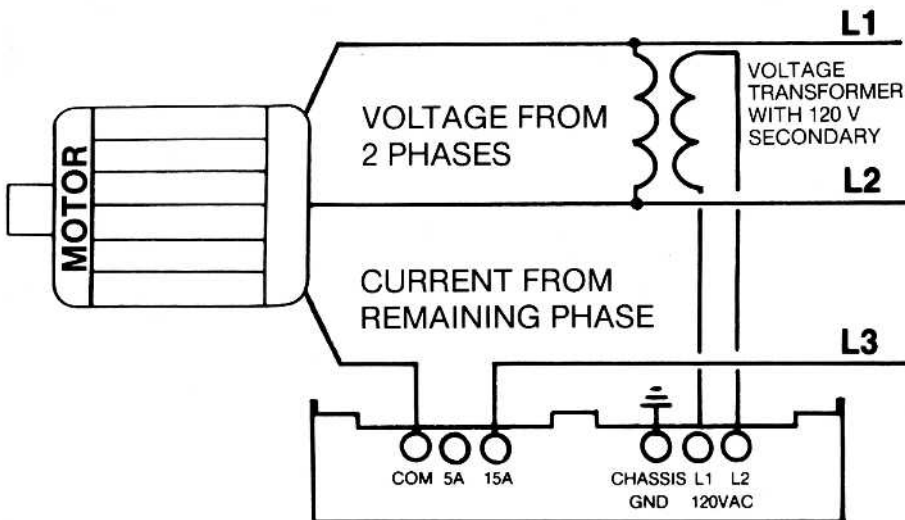

Over 15 Amps Use External
Current Transformer

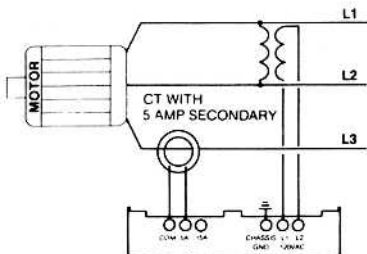

For Variable Frequency
Or DC Power Use Power
Cell Power Sensor and
"V" Series Load Control

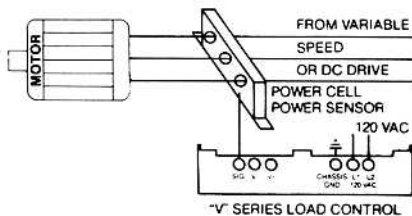

See Page 10 for CT Hookup

CONNECTING EXTERNAL CURRENT TRANSFORMER

For loads over 15 Amps, a Current Transformer is used to reduce the primary current to 5 Amps. Each time the primary wire goes through the center of the Current Transformer is a "Turn". Passing through the first time is 1 Turn. The proper number of Turns must be used to reach the desired rating. For most loads the CT 150:5 is used and the capacity is changed by changing the number of turns.

Connect the secondary leads to the COM and 5A Terminals on the Load Control.

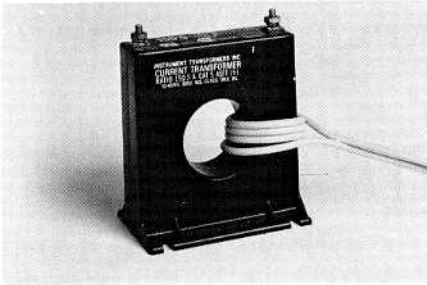

Secondary to Com & 5A Term.

	CT Size	Primary Turns	Capacity
CT 150:5 With 4 Turns	CT 150:5	6	25 AMPS
		5	30 AMPS
		4	37.5 AMPS
		3	50 AMPS
		2	75 AMPS
		1	150 AMPS
Larger CT's also available.	CT 100:5	1	100 AMPS
	CT 200:5	1	200 AMPS
	CT 250:5	1	250 AMPS
	CT 300:5	1	300 AMPS

The Full Scale Capacity (Sensitivity) of the Load Control can be fine tuned by adding or taking away Turns. More Turns = More Sensitivity. Fewer Turns = Less Sensitivity.

The Load Control is **NOT DAMAGED** by an overload. Don't be afraid to increase the sensitivity. More deflection means easier setting.

CAUTION

When current is flowing through the primary, always have the secondary wires either:

- Connected to the Load Control
- If the Load Control is removed, connected to each other.

If they are left open, dangerous and destructive voltages can develop.

RESET

Control can be reset 3 ways:

- Manually with the Reset button on the Control.
- Remotely with a remotely located Reset button.
- Automatically by jumpering the Reset Terminal. The Control will then automatically reset itself when the trip condition goes away.

HOOKUP

Remote Reset —

Momentarily Connect Terminal 2 to Terminal 5 for Set 1 & Set 2
Momentarily Connect Terminal 4 to Terminal 5 for Set 3

Automatic Reset —

Jumper Terminal 2 to Terminal 5 for Set 1 & Set 2
Jumper Terminal 4 to Terminal 5 for Set 3

INHIBIT

The Control can be inhibited or bypassed with the INHIBIT. This lets you ignore the Control during certain parts of the machine cycle, if you desire.

HOOKUP

Terminal 1 to Terminal 5

BASELINE

A COMPENSATED Set point needs a zero reference. This is done 2 ways: The first way is with a limit switch or programmable controller on the machine. Usually, an existing switch or controller is used as long as it is electrically compatible. The BASELINE signal should last at least 250 milliseconds but can be as long as you want. The COMPENSATOR™ remembers the last value before the BASELINE contact opens.

Secondly, the control also automatically establishes a Baseline when the Start-up timer goes off. If each machine cycle includes starting the motor, an external BASELINE is not needed.

You need a BASELINE update for each machine cycle. The green Baseline LED is on DURING the update.

HOOKUP

Momentarily connect Terminal 3 to Terminal 5.

Check the Load Meter as the Baseline LED goes out. This is the value that the COMPENSATOR™ remembers. It should be the idle load of the machine.

MANUAL BASELINE UPDATE

During machine setup it is sometimes helpful to manually update the BASELINE. Do this by momentarily jumpering Terminal 3 to Terminal 5.

ANALOG OUTPUT AND SET READ SWITCHES

Always use a Load Meter! It greatly simplifies setup, adjustment and trouble shooting.

The ANALOG OUTPUT (0-1 milliamp) proportional to motor power is on Terminal 6 (Positive) and Terminal 5 (Common). The Percent Load Meter is connected to this output.

- The Meter shows the Motor Load.
- When the Set Read switches are pressed, the Set Point is displayed.

The ANALOG OUTPUT can also be used to drive a chart recorder or as an input to a computer or controller.

The output can be factory modified for a 0-10V or 4-20 milliamp output. To convert the 0-1 milliamp output in the field to 0-10 volts, use a 10K ohm 1% resistor across Terminals 5 and 6.

HOOKUP

Terminal 6 Positive

Terminal 5 Common

Use #18 AWG or larger. For lengths of 10-100 feet, use shielded cable with the shield grounded at the Control, but not at the Meter.