

---

# INSTALLATION & OPERATION

---

## LCI MOTOR LOAD CONTROLS

---



## LCI Motor Load Controls Sense Motor Horsepower—

Use this valuable feedback to:

- Adjust Machines and Processes
- Signal Beginning or End of Process
- Detect Trouble
- Protect Machines and Processes

 **LOAD CONTROLS  
INCORPORATED**

53 TECHNOLOGY PARK RD.  
STURBRIDGE, MA 01566  
508-347-2606  
FAX 508-347-2064  
[www.loadcontrols.com](http://www.loadcontrols.com)

---

# POWER

---

The POWER to a motor measured in watts or horsepower is essentially linear for all motor loads and is the best indicator of the work being done by a motor. This is more sensitive than just sensing Amps.

These Controls have a built-in fast response Power Sensor

- Voltage is taken from two of the phases
- Current (amperage) is taken from the remaining phase
- Power Factor is calculated from the lag of the current behind the voltage

THREE PHASE POWER = VOLTS X AMPS X POWER FACTOR X 1.73

---

## FEATURES ON ALL CONTROLS

---

### ADJUSTABLE SET POINTS

When power reaches your selected SET POINT a built-in Relay Output is activated (tripped). Relay stays tripped (latched). You choose when to reset.

### ANALOG OUTPUT

Hook to the Load Meter for monitoring load, easy setup and adjustment.

### EASY SETUP WITH SET READ SWITCHES

Press the SET READ Switch and the SET POINT for that Channel is displayed on the LOAD METER.

- You **know** where the SET POINT is
- Easily verify proper operation

### BUILT-IN STARTUP TIMER

Adjustable Timer eliminates false trips while the Motor is starting.

### FILTER OUT NUISANCE TRIPS

Adjustable On-Delay Timer. Trip won't activate until the selected delay time is exceeded.

### RESET

The Control can be Reset

- Automatically — when the overload is gone
- Remotely — with switch, relay or programmable controller
- Manually

### TRIP INHIBIT

The Control can be remotely bypassed during any part of the cycle when not required.

### Also Available

Remote Set Point Adjustment for All Models

---

## STANDARD LOAD CONTROLS

---

The relays trip when a Set Point is reached. Set Points can be:

High Trip — Trips when the power goes above the Set Point

Low Trip — Trips when the power goes below the Set Point

---

## STANDARD LOAD CONTROL MODEL NUMBERS

---

**PFR-1500 Single Set Point**

One Set Point — High Trip

**PFR-1500L**

One Set Point — Low Trip

**PFR-1700 Dual Set Points**

Two Set Points — Both High Trip

**PFR-1700HL High-Low Set Points**

Two Set Points — One High Trip, One Low Trip

---

## COMPENSATOR™LOAD CONTROLS

---

For machine tool applications the IDLE or BASELINE power of a machine tool drifts because of changes in:

- Temperature
- Lubricant Viscosity
- Mechanical Clearance
- Idle Speed

For accurate dull or broken tool detection, grinder gap elimination, this drift should be zeroed out.

- A limit switch or programmable controller signal tells the COMPENSATOR™ each time the machine is in the idle or "BASELINE" position.
- The COMPENSATOR™ samples this power level and retains it as a reference.
- The SET POINTS are related to this BASELINE.

In other words, the COMPENSATOR™ zeros out the BASELINE power for each cycle. The absolute trip point changes as conditions change but always remains a fixed amount away from the BASELINE. This means no constant fine tuning. It adjusts itself.

---

## COMPENSATOR™LOAD CONTROLS MODEL NUMBERS

---

**PCR-1800 COMPENSATOR™**

Single Set Point Above the Compensating Baseline

**PCR-1810 COMPENSATOR™**

Two Set Points: One Compensating, One Standard

**PCR-1820 COMPENSATOR™**

Two Set Points, Both Compensating

---

# INSTALLATION

---

## MOUNTING

The Load Control should be mounted in a control cabinet or in a protected area. The four Phillips head screws on the Control should be removed and used for attaching the mounting brackets to the Control. High voltage is present on the upper terminal strips. If regular access to the Control is needed in this case, these terminals should be covered.

---

## ELECTRICAL CONNECTIONS

---

### VOLTAGE

120 Volts AC - 35VA minimum is taken from two of the phases. If the machine already has a 120 Volt control transformer with 35 VA of free capacity, this can be used. Otherwise, install a separate transformer. Be sure to note which two phases supply the transformer.

### CURRENT

The current signal is taken from the **REMAINING** phase. There is a current sensing toroid inside the control and up to 15 Amps can be passed directly through the control. The normal control has full scale capacities of 3.75, 5 and 15 Amps built-in. Above 15 Amps, an external current transformer reduces the signal to 5 Amps which is then passed through the control. For small motors, the control can easily be factory modified. A standard modification is .75, 1.0, 3.0 Amps full scale.

It is **VERY IMPORTANT** that the current signal comes from the phase that IS NOT supplying the 120V control transformer. Be extra careful when the machine has reversing starters or multi-speed windings. If a wrong phase is used the control will either:

- Work backwards
- Have reduced sensitivity.

### CAPACITY

Below 2 Amps  
3.75 Amps  
5 Amps  
15 Amps  
Above 15 Amps Use  
xxx: 5 Current Transformer

### CONNECT CURRENT TO TERMINALS

\*MODEL "1.0" Factory Modification  
5A and 15A  
COM and 5A  
COM and 15A  
COM and 5A

\*For Small Motors  
Specify Suffix "1.0"  
Full Scale .75 Amp, 1 Amp, 3 Amp

# ELECTRICAL CONNECTIONS (Continued)

Up to 15 Amps Directly  
Through Control

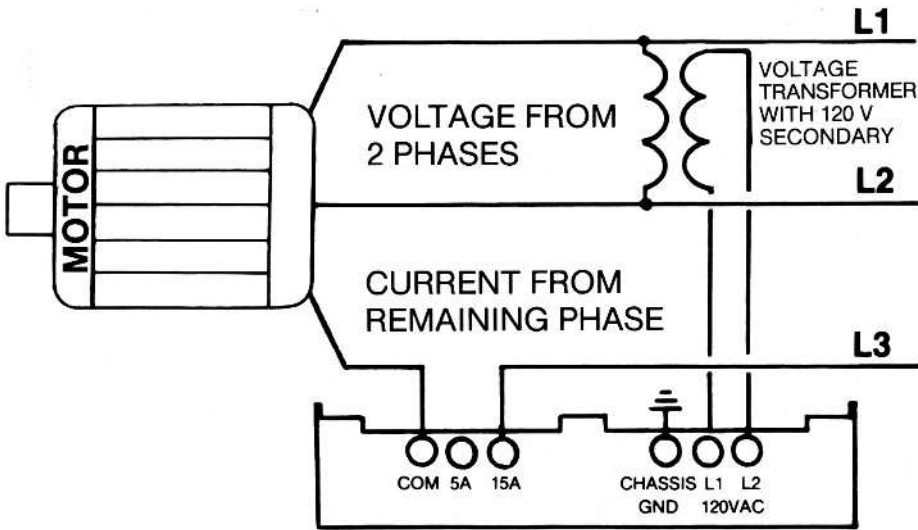

Over 15 Amps Use External  
Current Transformer

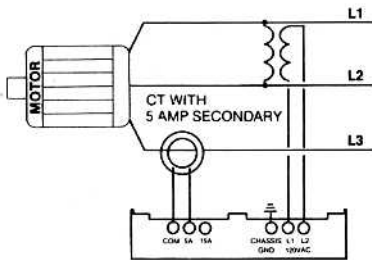

For Variable Frequency  
Or DC Power Use Power  
Cell Power Sensor and  
"V" Series Load Control

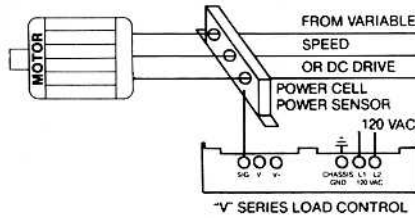

See Page 10 for CT Hookup

## OUTPUT CONNECTIONS (Terminals 7-12)

### RELAY OUTPUTS — SINGLE SET POINT CONTROLS

PFR-1500  
PFR-1500L  
PCR-1800

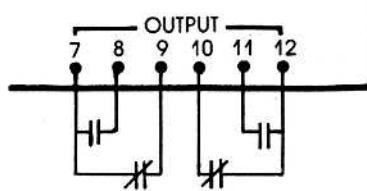

### RELAY OUTPUTS — TWO SET POINT CONTROLS

PFR-1700  
PFR-1700HL  
PCR-1810  
PCR-1820

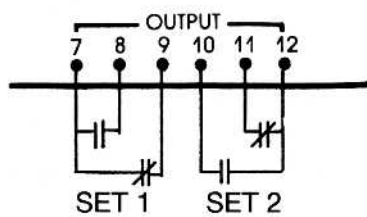

(Set 1 is the low set point  
for model PFR-1700HL)

- **Relays Shown Normal Operation**
- **Power On**
- **Not Tripped**
- Specifications: .01 Amps to 3 Amps at 120 Volts AC  
1/20 HP at 120 Volts AC

## CONTROL CONNECTIONS (Terminals 1-6)

### ANALOG OUTPUT AND SET READ SWITCHES

**Always use a Load Meter! It greatly simplifies setup, adjustment and trouble shooting.**

The ANALOG OUTPUT (0-1 milliamp) proportional to motor power is on Terminal 6 (Positive) and Terminal 5 (Common). The Percent Load Meter is connected to this output.

- The Meter shows the Motor Load.
  - When the Set Read switches are pressed, the Set Point is displayed.
- The ANALOG OUTPUT can also be used to drive a chart recorder or as an input to a computer or controller.

The output can be factory modified for a 0-10V or 4-20 milliamp output. To convert the 0-1 milliamp output in the field to 0-10 volts, use a 10K ohm 1% resistor across Terminals 5 and 6.

### HOOKUP

#### Terminal 6 Positive

#### Terminal 5 Common

Use #18 AWG or larger. For lengths of 10-100 feet, use shielded cable with the shield grounded at the Control, but not at the Meter.

---

## **HOOKING UP RESET, INHIBIT AND BASELINE**

---

The terminals for BASELINE, RESET and INHIBIT generate a small amount of current (8-12 milliamps). To activate one of these functions you just need to connect the terminal to the circuit common (Terminal 5).

The switches or relays that you use must be suitable for low current. (Gold flashed contacts, Reed Relays, Mercury Switches, Open Collectors).

***Don't use 10 Amp switches. They won't be reliable.***

A voltage signal from a programmable controller can also be used but it must be a sink or source/sink (30 Volt max., 12 Volt min). When in doubt, use a reed relay.

***Don't put 120V on Terminals 1-6. It will destroy the control.***

### **RESET**

Control can be reset 3 ways:

- Manually with the Reset button on the Control.
- Remotely with a remotely located Reset button.
- Automatically by jumpering the Reset Terminal. The Control will then automatically reset itself when the trip condition goes away.

### **HOOKUP**

#### **Remote Reset —**

- Momentarily Connect Terminal 2 to Terminal 5 for Set 1**
- Momentarily Connect Terminal 4 to Terminal 5 for Set 2**

#### **Automatic Reset —**

- Jumper Terminal 2 to Terminal 5 for Set 1**
- Jumper Terminal 4 to Terminal 5 for Set 2**

### **INHIBIT**

The Control can be inhibited or bypassed with the INHIBIT. This lets you ignore the Control during certain parts of the machine cycle, if you desire.

### **HOOKUP**

**Terminal 1 to Terminal 5**

# **HOOKING UP RESET, INHIBIT AND BASELINE** (Continued)

## **BASELINE**

**(For COMPENSATOR™ Models PCR-1800, PCR-1810, PCR-1820)**

A COMPENSATED Set Point needs a zero reference. This is done 2 ways: The first way is with a limit switch or programmable controller on the machine. Usually, an existing switch or controller is used as long as it is electrically compatible. The BASELINE signal should last at least 250 milliseconds but can be as long as you want. The COMPENSATOR™ remembers the last value before the BASELINE contact opens.

You need a BASELINE update for each machine cycle. The green Baseline LED is on DURING the update.

The control also automatically establishes a Baseline when the Startup timer goes off. If each machine cycle includes starting the motor, an external BASELINE is not needed.

## **HOOKUP**

**Momentarily connect Terminal 3 to Terminal 5.**

Check the Load Meter as the Baseline LED goes out. This is the value that the COMPENSATOR™ remembers. It should be the idle load of the machine.

## **MANUAL BASELINE UPDATE**

During machine setup it is sometimes helpful to manually update the BASELINE. Do this by momentarily jumpering Terminal 3 to Terminal 5.

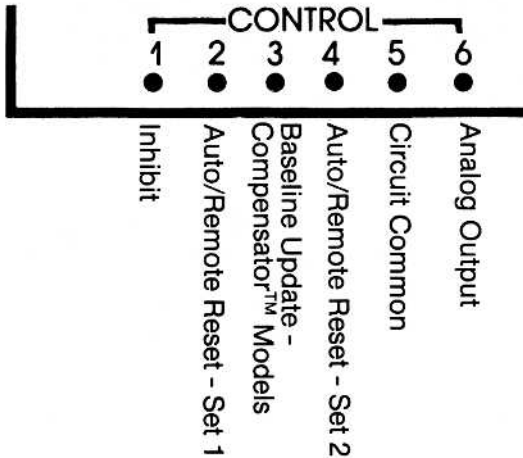

***Don't put 120 volts on Terminals 1-6! It will destroy the control.***



